

# SCHALTPLAN



KBS Gastrotechnik GmbH – Schoßbergstraße 26 – 65201 Wiesbaden

# REFRIGERATOR

Model: CUBE	Refrigerant & Injection(g): R134a & 200
Product code: 9160270	Type of Climate: 6
General Rated Input Power(W): 475	Protected Mode: I
Refrigeration Temperature(°C): 2-8	Storage Volume(L): 270
Rated Frequency(Hz): 50	Rated Voltage(V): 220-240~
Rated Current(A): 2.75	Lamp power(W): 15(LED)
Overall Dimension(mm): 915x675x1210	Net Weight(kg): 120
Package Dimension(mm): 1025x765x1280	
Foaming agent: EPS	

Produce Date & Code:

Circuit Diagram

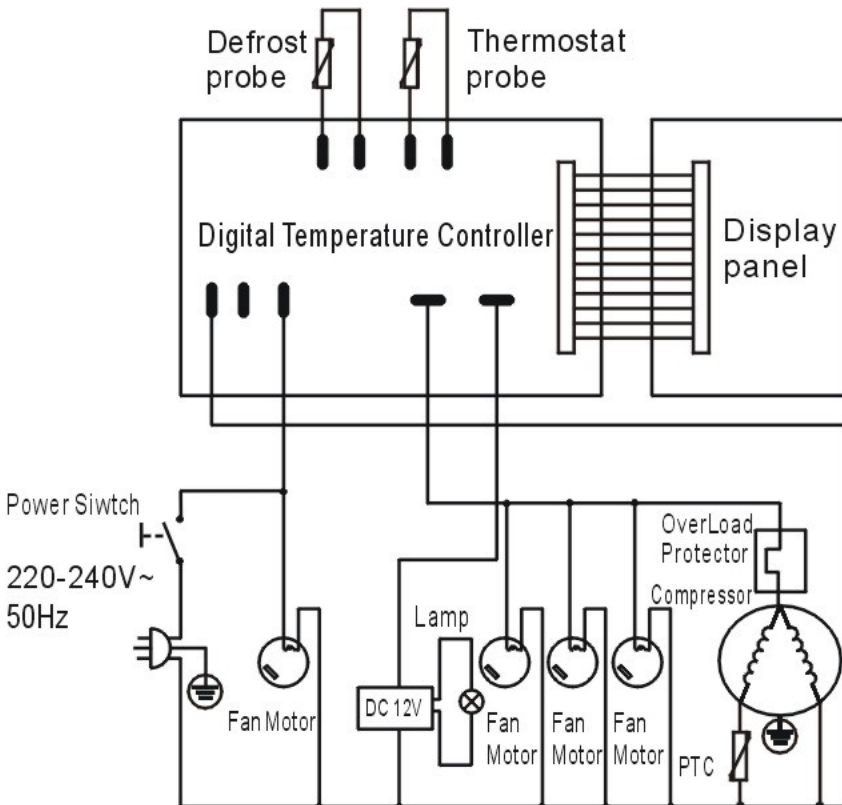

**KBS Gastrotechnik GmbH,**  
**Johannes-Kepler Straße 14, 55129 Mainz**