

SCHALTPLAN



KBS Gastrotechnik GmbH – Schoßbergstraße 26 – 65201 Wiesbaden

ROTATIONAL DISPLAYS

Model: SC100	Refrigerant&Injection(g):R600a(53)
Product code: 9160100	Type of Climate:N
General Rated Input Power(W): 230	Protected Mode: I
Refrigeration Temperature(°C): 2-10	Rated Voltage(V): 220-240~
Storage Volume(L):108	Rated Frequency(Hz): 50
Net Weight(kg): 52	Rated Current (A):1.3
Maximum load(kg):10	Lamp Power(W): 1.5*2(LED)
Overall Dimension(mm): 470x470x870	Package Dimension(mm): 560x530x938

Produce Date &Code:

Circuit Diagram

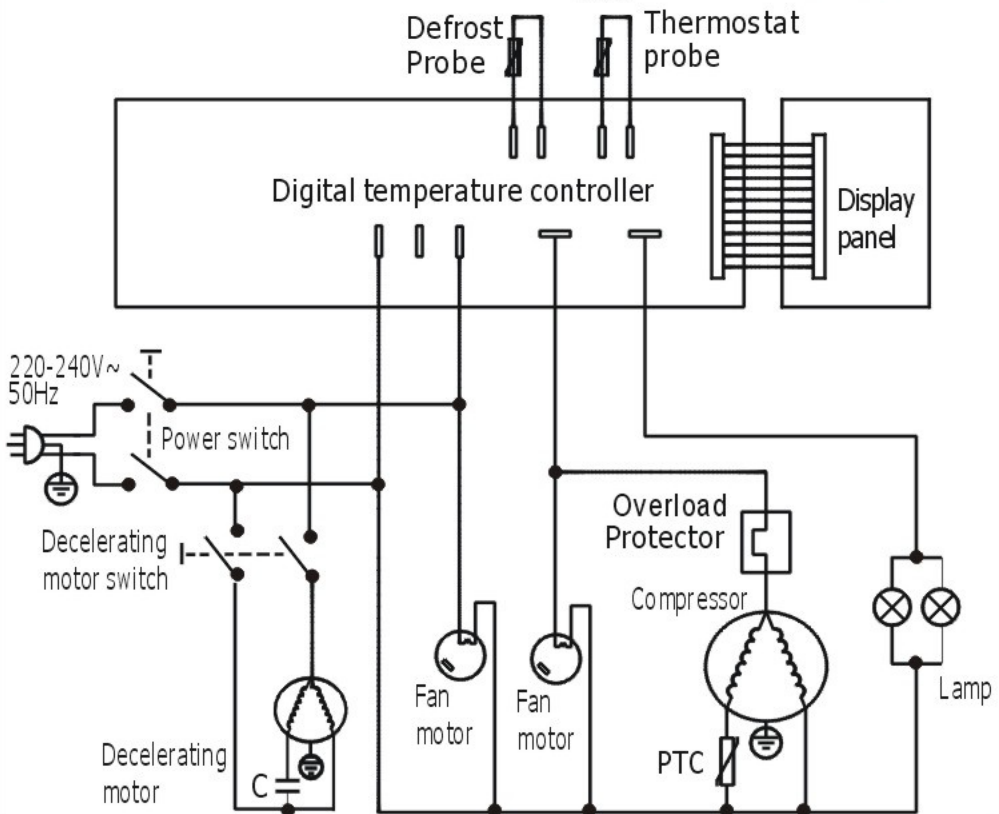

KBS Gastrotechnik GmbH,
Johannes-Kepler Straße 14, 55129 Mainz