

SCHALTPLAN



KBS Gastrotechnik GmbH – Schoßbergstraße 26 – 65201 Wiesbaden

Open Display

Model: ALVIN	Refrigerant&Injection(g):R404a&340
Product code: 9150224	Type of Climate:6
General Rated Input Power(W): 1340	Refrigeration Temperature(°C): 2-10
Power running of electrical heating element(W): 490	Max. ambienttemp./RH: <27°C/70%
Net Weight(kg): 96	Storage Volume(L):220
Lamp power(W):1.44*4(LED)	Rated Voltage(V): 230~
Overall Dimension(mm):674x494x1742	Rated Frequency(Hz): 50
Package Dimension(mm): 720x565x1808	Rated Current (A):8
Foaming agent:XPS	

Produce Date & Code:

Circuit Diagram

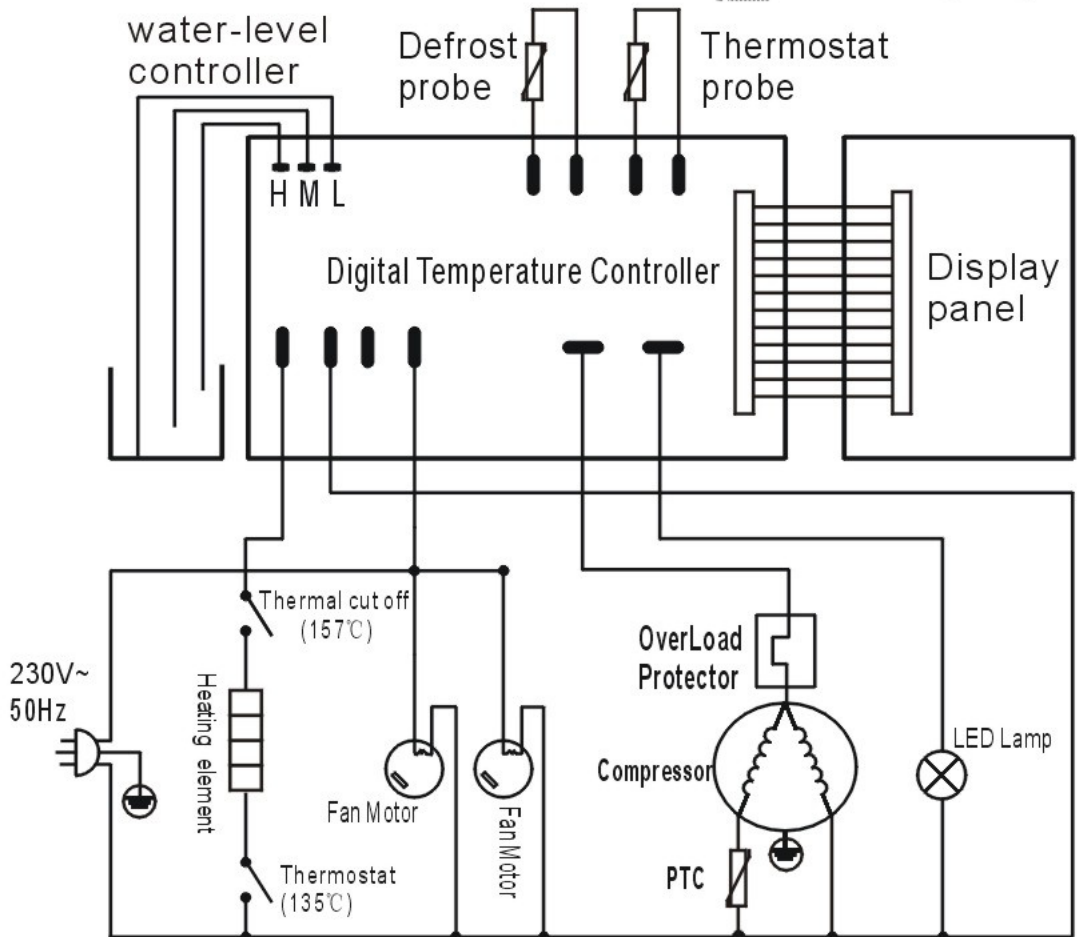

KBS Gastrotechnik GmbH,
Johannes-Kepler Straße 14, 55129 Mainz