

FRONT VIEW 1:10

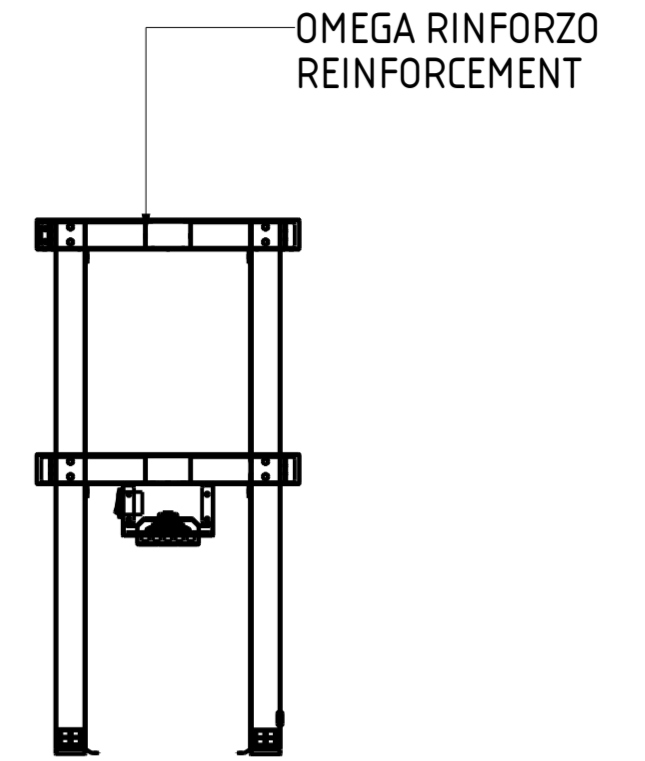

B-B

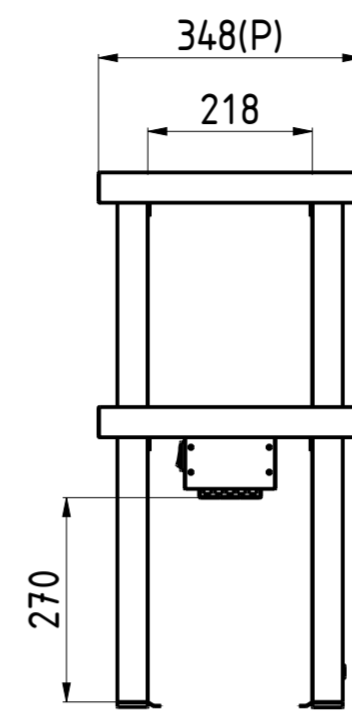
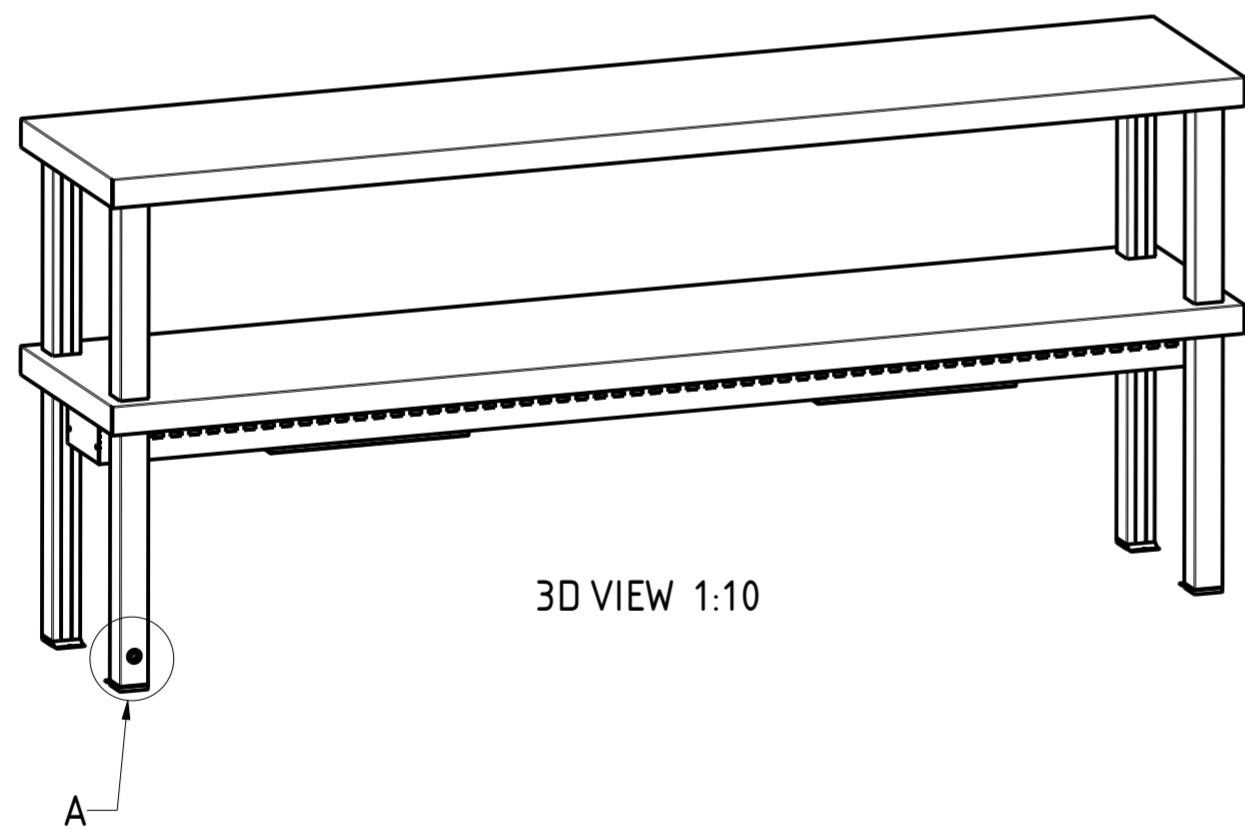

3D VIEW 1:10

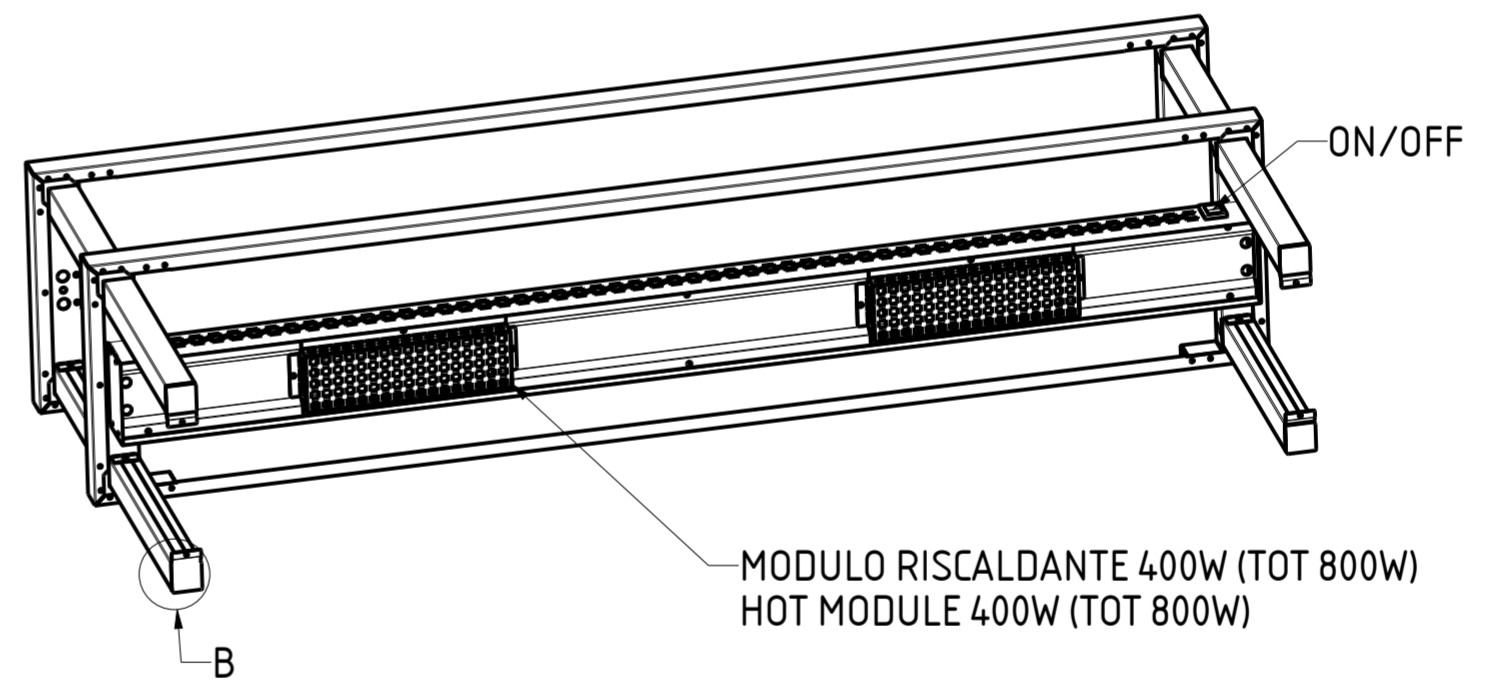

3D BOTTOM VIEW 1:10

USCITA CAVO ALIMENTAZIONE
POWER SUPPLY OUTPUT

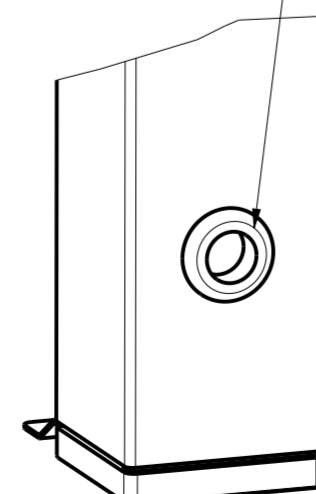

A(7:10)

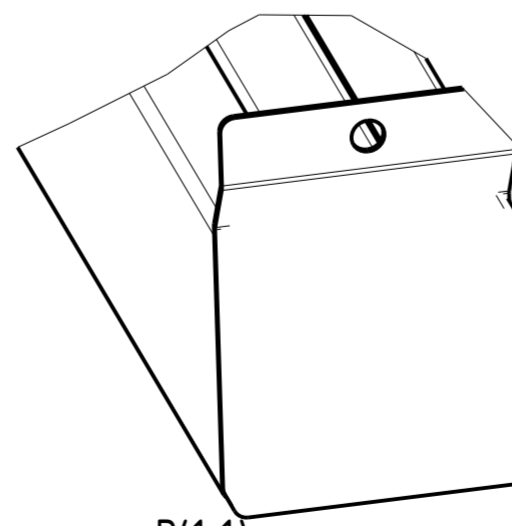

B(1:1)

DATA DATE	MODIF. N. MODIF. NO.	DESCRIZIONE MODIFICHE MODIFICATION DESCRIPTION	DISegnATO DRAWN BY	APPROVATO APPROVED
MODELLO MODEL	RIPIANO DI APPOGGIO DOPPIO RISCALDATO H70 CM TABLES TOPS - TOP AND SHELF WITH HEATING H70 CM		DISegno N. DRAWING NO. DSRADR16357	SCALA SCALE -
PARTICOLARE DETAIL	SCHEDA TECNICA DATA SHEET		DISegnATO DRAWN BY M.PAPI	DATA DATE
MATERIALE MATERIAL	SPES.S. THICK.	APPROVATO APPROVED	SHEET 1 OF 2	
FINITURA FINISH	PEZZI N. PIECES NO.	SOSTITUISCE IL DIS. N. IT REPLACES DRAWING NO.	ULTIMA EMISS. LAST EDITION	
TRATTAMENTO TREATMENT	COLORE COLOUR	SOSTITUITO DAL DIS. N. REPLACED BY DRAWING NO.		
RISTOPRO PROFESSIONAL CATERING EQUIPMENT		RISTOPRO SRL FRAZ. BORGO TUFICO, 47 FABRIANO (AN) ITALY +39.732.043494 WWW.RISTOPRO.COM		mm

ELABORATO CON SISTEMA CAD DESIGNED BY CADSYSTEM
 QUOTA PRIMARIA PRIMARY DIMENSION XX
 ANGOLI Angles 30° ±0.30°
 TOLLERANZA UNLESS OTHERWISE STATED
 QUOTE SENZA TOLLERANZA
 >500 ±0.75
 400-500 ±0.65
 315-400 ±0.60
 250-315 ±0.55
 180-250 ±0.50
 120-180 ±0.45
 80-120 ±0.40
 50-80 ±0.35
 30-50 ±0.30
 18-30 ±0.25
 10-18 ±0.20
 5-10 ±0.15
 0-5 ±0.10
 LUNGH. E DIAM. LENGTH AND DIAM. mm
 FORM.A-2

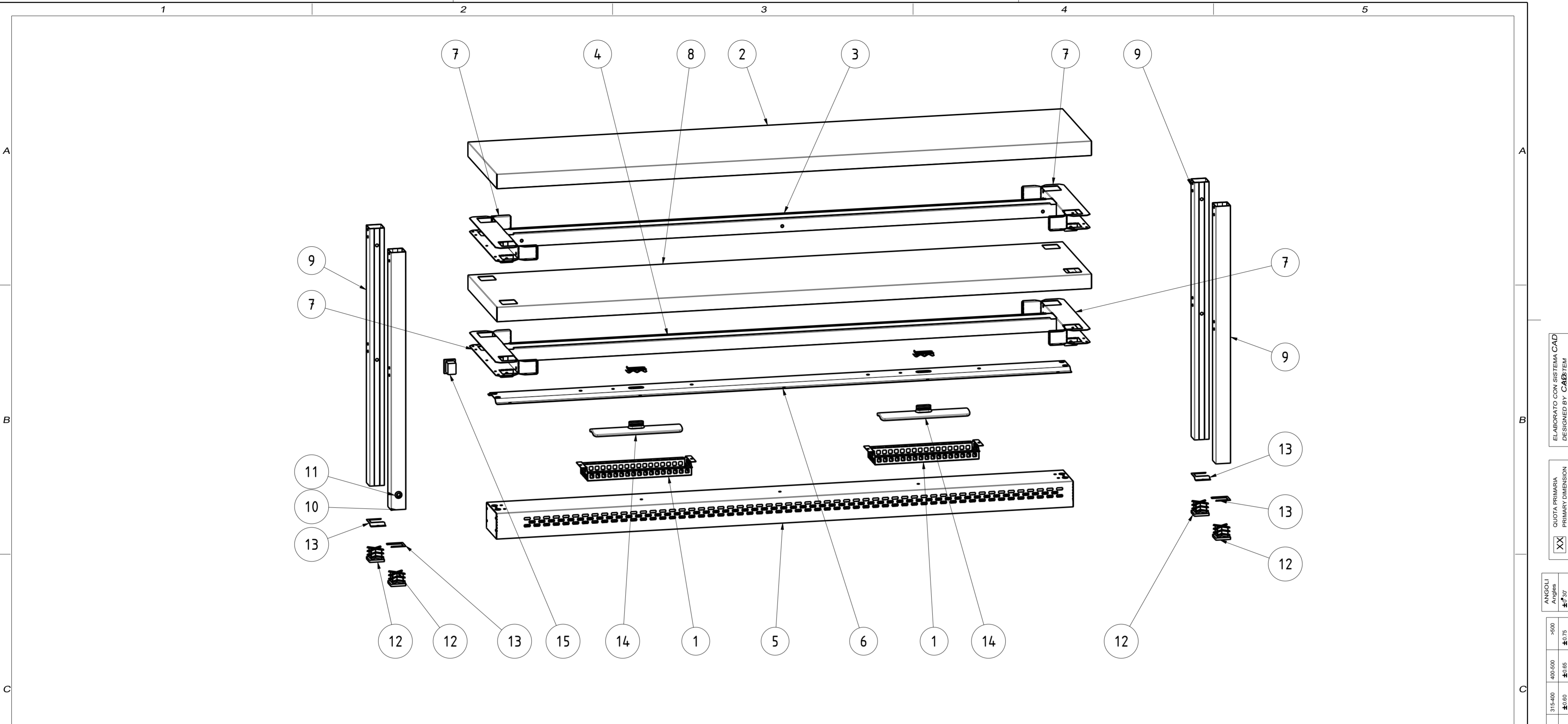

15	TASTO_ON_OFF_SCALDAVIVANDE	1	TASTO_ON_OFF	ON/OFF BUTTON
14	RESISTENZA	2	RESISTENZA	RESISTENCE
13	RA11	4	STAFFA FISSAGGIO AL TAVOLO	FIXING BRACKET
12	QA40	4	COPRITESTA 40x40x6	PLASTIC HEAD COVER
11	PASSACAVO_9_5	1	PASSACAVO 9-5	FAIRLEAD 9-5
10	NT14166	1	GAMBA QUADRA H70 PASSACAVO SCALDAVIVANDE	FAIRLEAD SQUARE LEG H70
9	NT14165	3	GAMBA QUADRA H70 PER SCALDAVIVANDE	SQUARE LEG H70
8	NT3698	1	RIPIANO INF GAMBE QUAD. SCALDAV. 160x35	LOWER SHELF 160x35
7	NT3321	4	SUPP.GAMBE QUADRE INFER.SCALDAVIVANDE P35	LOWER SQUARE LEGS SUPPORT P35
6	NT1909	1	SUPP. RESISTENZA INTERNO SCALDAVIVANDE L160	INTERNAL RESISTANCE SUPPORT L160
5	NT1908	1	SUPP. RESISTENZA ESTERNO SCALDAVIVANDE L160	SUPPORT FOR EXTERNAL HEATING WARMER L160
4	NT1907	1	TRAVERSA DI RINF. INFER. SCALDAVIVANDE L160	LOWER REINFORCEMENT L160
3	NT1905	1	160_SUPERIORE	UPPER REINFORCEMENT L120
2	NT1900	1	RIPIANO SUP SCALDAV. 160x35	UPPER SHELF 160x35
1	NT774	2	COPERTURA RESISTENZA	RESISTENCE COVER
ITEM NO	PART NUMBER	QTY	DESCRIPTION	

DATA DATE	MODIF.N. MODIF.NO.	DESCRIZIONE MODIFICHE MODIFICATION DESCRIPTION	DISegnATO DRAWN BY	APPROVATO APPROVED
MODELLO MODEL	RIPIANO DI APPOGGIO DOPPIO RISCALDATO H70 CM TABLES TOPS - TOP AND SHELF WITH HEATING H70 CM		DISEGNO N. DRAWING NO. DSRADR16357	SCALA SCALE -
PARTICOLARE DETAIL	SCHEDA TECNICA DATA SHEET		DISEGNATO DRAWN BY M.PAPI	DATA DATE
MATERIALE MATERIAL	SPES.S THICK.	APPROVATO APPROVED	SHEET 2 OF 2	
FINITURA FINISH	PEZZI N. PIECES NO.	SOSTITUISCE IL DIS. N. IT REPLACES DRAWING NO.	ULTIMA EMISS. LAST EDITION	
TRATTAMENTO TREATMENT	COLORE COLOUR	SOSTITUITO DAL DIS. N. REPLACED BY DRAWING NO.		
RISTOPRO PROFESSIONAL CATERING EQUIPMENT		RISTOPRO SRL FRAZ. BORGO TUFICO, 47 FABRIANO (AN) ITALY +39.732.043494 WWW.RISTOPRO.COM		 mm

TOLLERANZA UNLESS OTHERWISE STATED
 QUOTE SENZA TOLLERANZA
 TOLERANCE UNLESS OTHERWISE STATED
 QUOTE WITHOUT TOLERANCE
 ELABORATO CON SISTEMA CAD
 DESIGNED BY CAD/STEM
 QUOTA PRIMARIA
 PRIMARY DIMENSION
 XX
 ANGOLI
 Angles
 >500 ±0.75
 400-500 ±0.65
 315-400 ±0.60
 250-315 ±0.55
 120-180 ±0.45
 80-120 ±0.40
 50-80 ±0.35
 30-50 ±0.30
 10-18 ±0.25
 5-10 ±0.15
 0-5 ±0.10
 LUNGH. E DIAM.
 LENGTH AND DIAM.
 mm
 FORM.A-2