

SCHALTPLAN

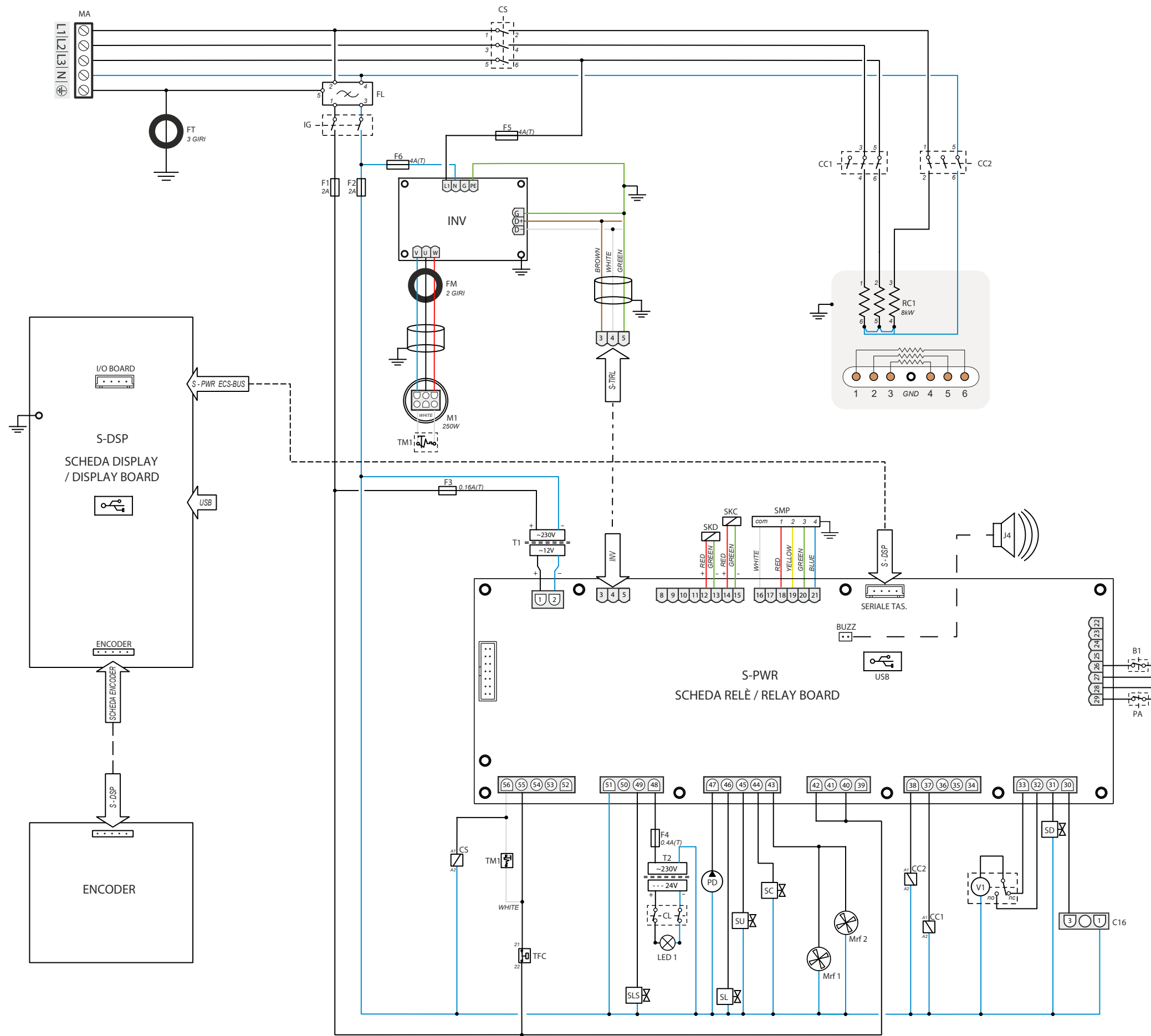

KBS Gastrotechnik GmbH – Schoßbergstraße 26 – 65201 Wiesbaden



- B1** : Micro porta / door switch
- C16** : Contatto comando cappa / hood control contact
- CC1** : Contattore potenza camera / chamber power contactor
- CC2** : Contattore potenza ridotta camera / chamber reduced power contactor
- CL** : Contatto luci porta / door light contact
- CS** : Contattore sicurezza camera / chamber safety contactor
- F1** : Fusibile fase / phase fuse 2A-250V-5x20
- F2** : Fusibile neutro / neutral fuse 2A-250V-5x20
- F3** : Fusibile scheda / board fuse 0.16A(T)-250V-5x20
- F4** : Fusibile barra led / led strip fuse 0.4A(T)-250V-5x20
- F5** : Fusibile fase inverter / inverter phase fuse 4A(T)
- F6** : Fusibile neutro inverter / inverter neutral fuse 4A(T)
- FL** : Filtro di linea / phase filter
- FM** : Ferrite motore / motor ferrite filter
- FT** : Ferrite terra / ground ferrite filter
- IG** : Interruttore generale / main switch
- INV** : Inverter motore / motor inverter
- LED 1** : Barra led / led strip
- M1** : Motore superiore / upper motor
- MA** : Morsettiera allacciamento / connection terminal block
- Mrf 1** : Ventilatore raffredd. cruscotto / dashboard cooling fan
- Mrf 2** : Ventilatore raffredd. schiena / back cooling fan
- PA** : Pressostato acqua / water inlet pressure switch
- PD** : Pompa detergente camera / chamber detergent pump
- RC 1** : Resistenza camera / chamber resistance
- S-PWR** : Scheda base relè / relay base board
- S-DSP** : Scheda display / display board
- SC** : Elettrovalvola condensazione / condensation solenoid valve
- SD** : Elettrovalvola scarico detergente / detergent drain solenoid valve
- SKC** : Sonda temp. camera / chamber Temp. probe
- SKD** : Sonda temp. condensazione / condensation Temp.probe
- SL** : Elettrovalvola lavaggio camera / chamber washing solenoid valve
- SLS** : Elettrovalvola scarico lavaggio / washing drain solenoid valve
- SMP** : Sonda temp. sonda al cuore / core Temp. probe
- SU** : Elettrovalvola umidificatore / humidification solenoid valve
- T1** : Trasformatore scheda tastiera / display b. transformer
- T2** : Trasformatore barra led / LED strip transformer
- TFC** : Termostato sicurezza camera / chamber safety thermostat
- TM 1** : Termico motore / motor thermal switch
- V1** : Programmatore sfiato / vent programmer

SCHEMA / DRAWING
5416.440.00

MODELLO / MODEL
**ECM06DSL
ECM06TSL**

**400V ~3N
50-60HZ
8.25 kW**

TIPO DI CAVO / CABLE TYPE
Sezione min. / Min.cross section: **5 × 10 mm²**
Tipo di cavo / Cable Type: **H07 RN-F**
Lunghezza max cavo / Max cable lenght: **2 m**

