

SCHALTPLAN

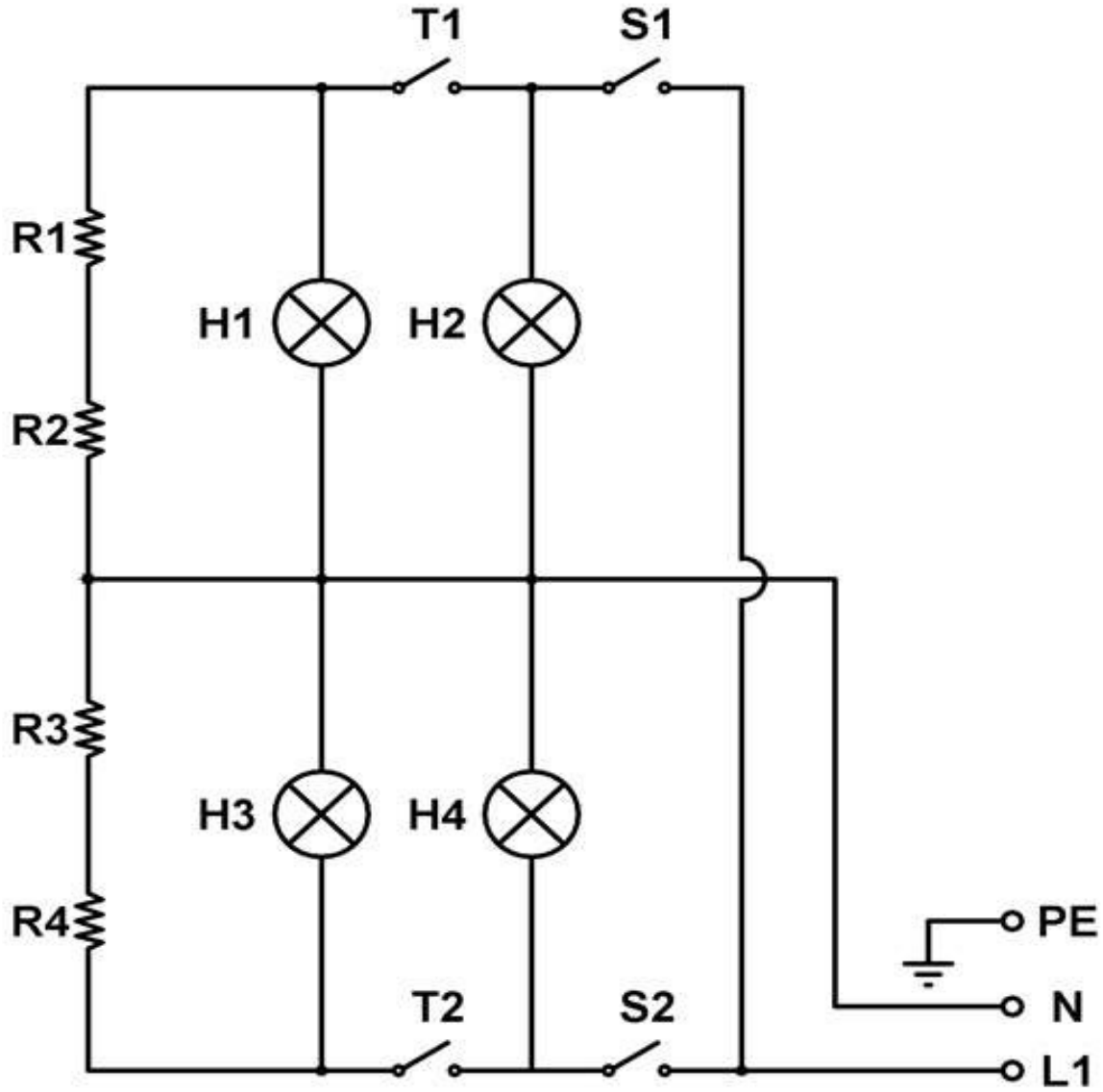

KBS Gastrotechnik GmbH – Schoßbergstraße 26 – 65201 Wiesbaden

WE 22 WAFFLE MAKİNASI - ELEKTRİK ŞEMASI
WE 22 WAFFLE MACHINE ELECTRICAL CIRCUIT DIAGRAM



NO	AÇIKLAMA / DESCRIPTION	NO	AÇIKLAMA / DESCRIPTION
R1 - R3	Rezistans / Resistance (1100 W)	S1 - S2	Şalter / Power Switch
R2 - R4	Rezistans / Resistance (1100 W)	H1 - H4	Şalter Kontrol Lambası (Kırmızı) Power Switch Control Lamps (Red)
T1 - T2	Termostat / Thermostat (52 - 310 °C)	H2 - H3	Termostat Kontrol Lambası (Yeşil) Thermostat Control Lamps (Green)