

SCHALTPLAN

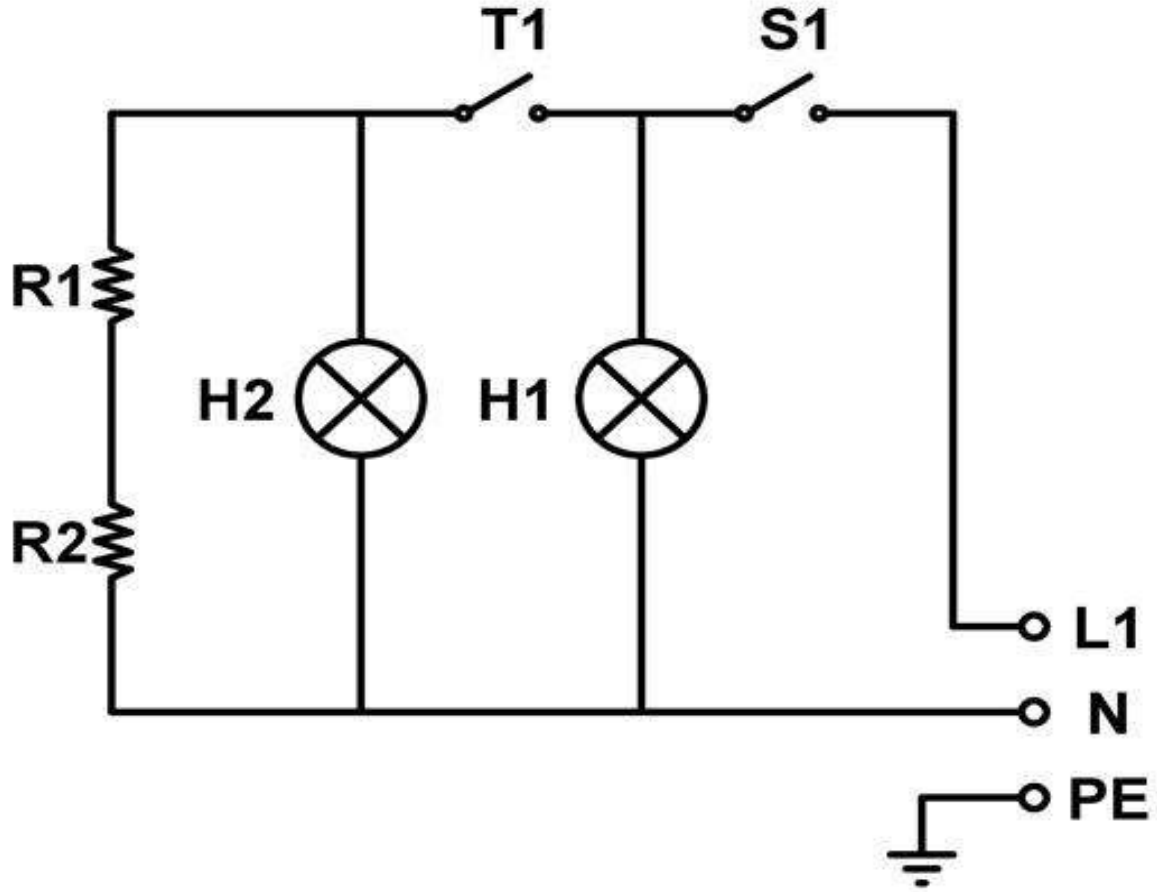

KBS Gastrotechnik GmbH – Schoßbergstraße 26 – 65201 Wiesbaden

WE 02 WAFFLE MAKİNASI - ELEKTRİK ŞEMASI
WE 02 WAFFLE MACHINE - ELECTRICAL CIRCUIT DIAGRAM



NO	AÇIKLAMA / DESCRIPTION	NO	AÇIKLAMA / DESCRIPTION
R1	Rezistans / Resistance (1100 W)	S1	Şalter / Power Switch
R2	Rezistans / Resistance (1100 W)	H1	Şalter Kontrol Lambası (Kırmızı) Power Switch Control Lamps (Red)
T1	Termostat / Thermostat (52 - 310 °C)	H2	Termostat Kontrol Lambası (Yeşil) Thermostat Control Lamps (Green)