

SCHALTPLAN

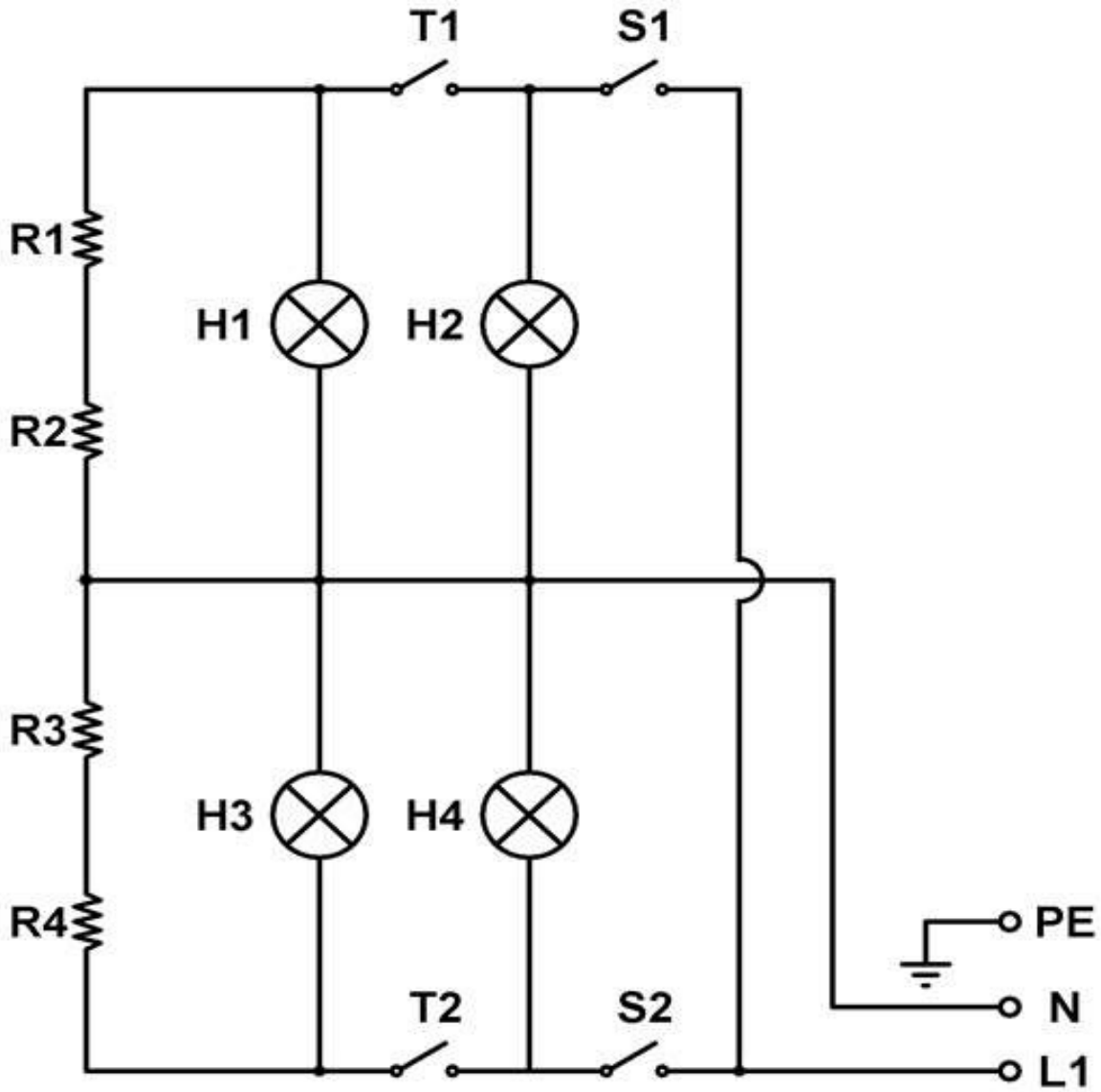

KBS Gastrotechnik GmbH – Schoßbergstraße 26 – 65201 Wiesbaden

KGW 5530 WE WAFFLE MAKİNASI - ELEKTRİK ŞEMASI
KGW 5530 WE WAFFLE MACHINE ELECTRICAL CIRCUIT DIAGRAM



| NO | AÇIKLAMA / DESCRIPTION | NO | AÇIKLAMA / DESCRIPTION |
|---------|---|---------|---|
| R1 - R3 | Rezistans / Resistance (1100 W) | S1 - S2 | Şalter / Power Switch |
| R2 - R4 | Rezistans / Resistance (1100 W) | H1 - H4 | Şalter Kontrol Lambası (Kırmızı) Power Switch Control Lamps (Red) |
| T1 - T2 | Termostat / Thermostat (52 - 310 °C) | H2 - H3 | Termostat Kontrol Lambası (Yeşil) Thermostat Control Lamps (Green) |