

# SCHALTPLAN

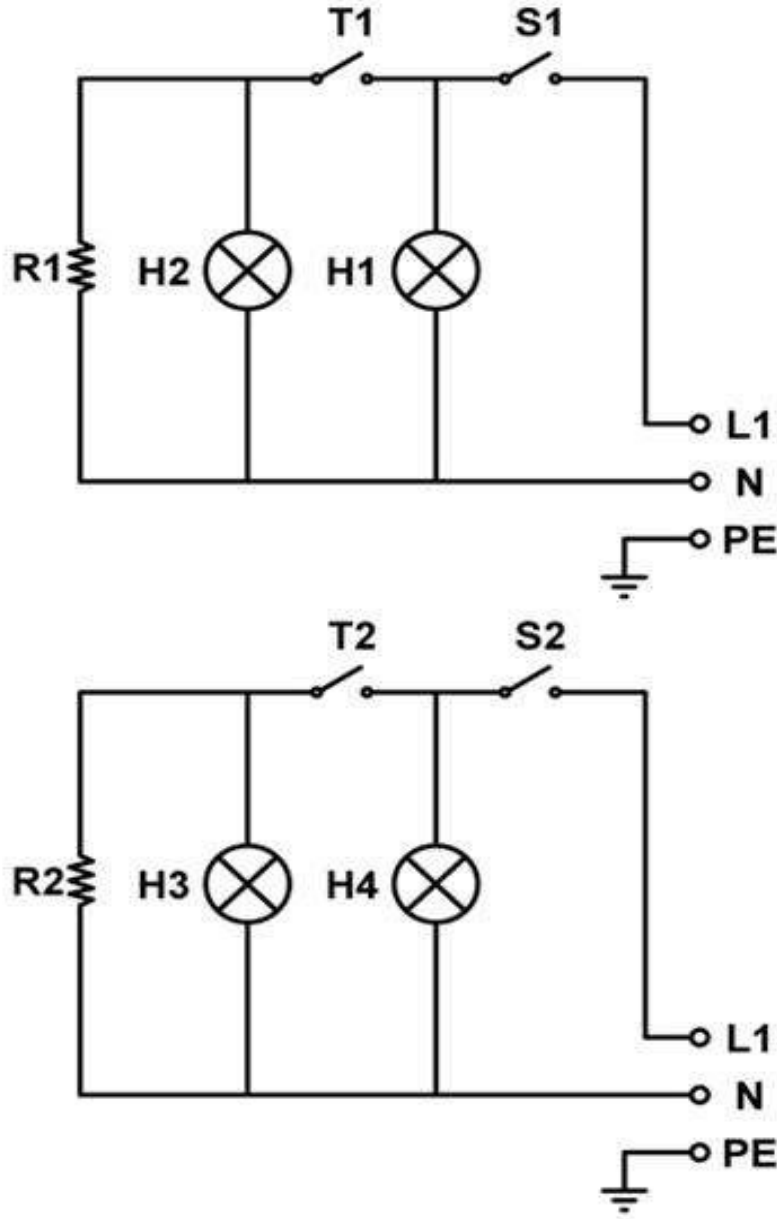

KBS Gastrotechnik GmbH – Schoßbergstraße 26 – 65201 Wiesbaden

**CR - D 240 KREP MAKİNASI - ELEKTRİK ŞEMASI**  
**CR - D 240 CREPE MACHINE - ELECTRICAL CIRCUIT DIAGRAM**



NO	AÇIKLAMA / DESCRIPTION	NO	AÇIKLAMA / DESCRIPTION
R1	Rezistans / Resistance ( 3000 W )	S1 - S2	Şalter / Power Switch
R2	Rezistans / Resistance ( 3000 W )	H1 - H4	Şalter Kontrol Lambası ( Kırmızı ) Power Switch Control Lamps ( Red )
T1 - T2	Termostat / Thermostat ( 52 - 310 °C )	H2 - H3	Termostat Kontrol Lambası ( Yeşil ) Thermostat Control Lamps ( Green )