

SCHALTPLAN

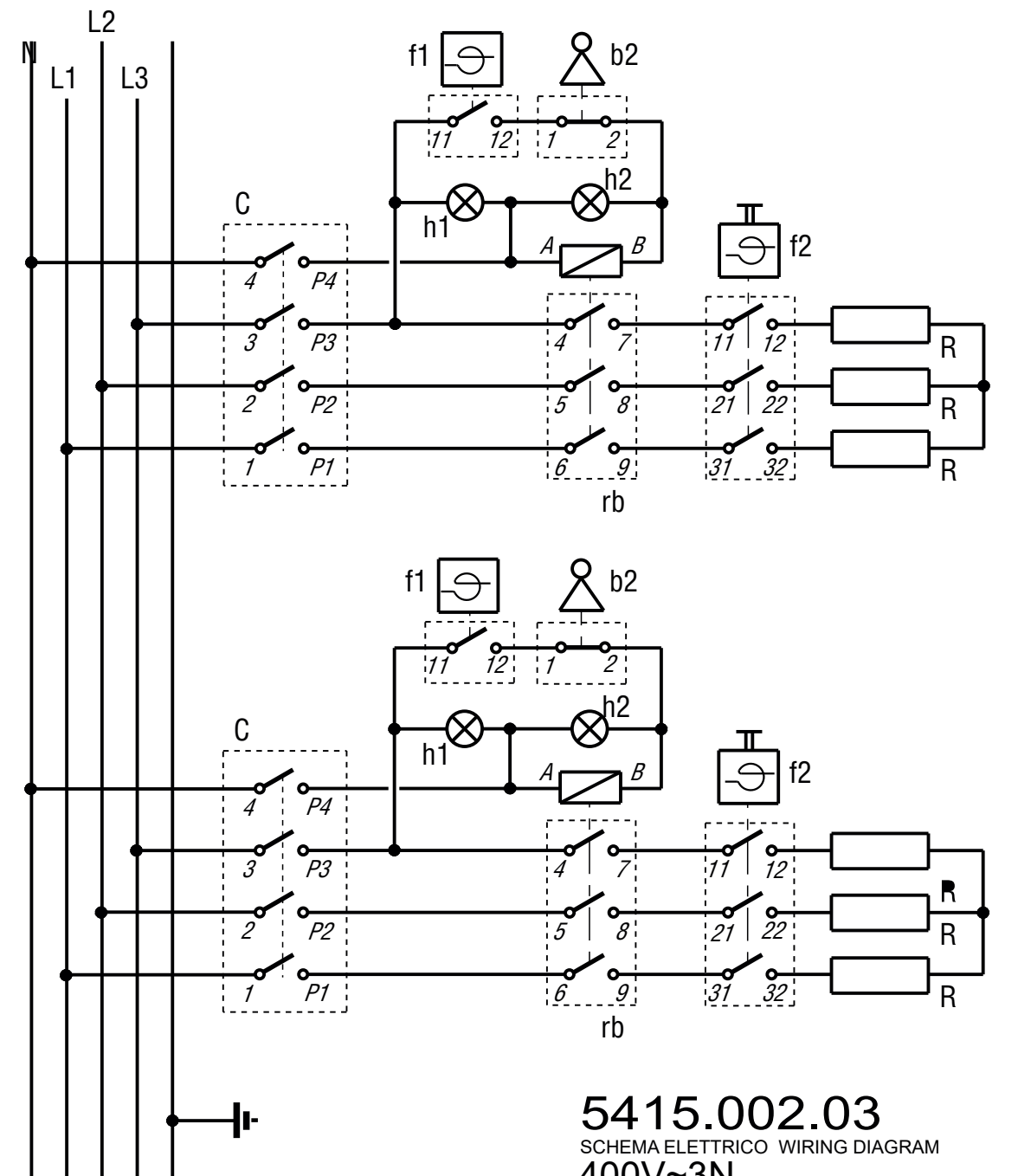

KBS Gastrotechnik GmbH – Schoßbergstraße 26 – 65201 Wiesbaden

f2	Limitatore di temperatura	Temperature Limiting Device
f1	Termostato di lavoro	Thermostat
b2	Interruttore di sicurezza	Security Switch
h2	Lampada resistenza inserita (arancio)	Running Heating Element Lamp (orange)
h1	Lampada presenza tensione (verde)	Tension Signal Lamp (green)
C	Commutatore	Switch
rb	Relè	Remote control switch
R	Resistenza elettrica	Heating Element
m	Morsettiera	Main Terminal Block

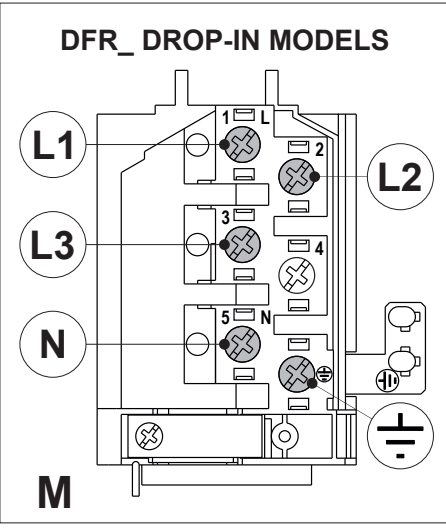
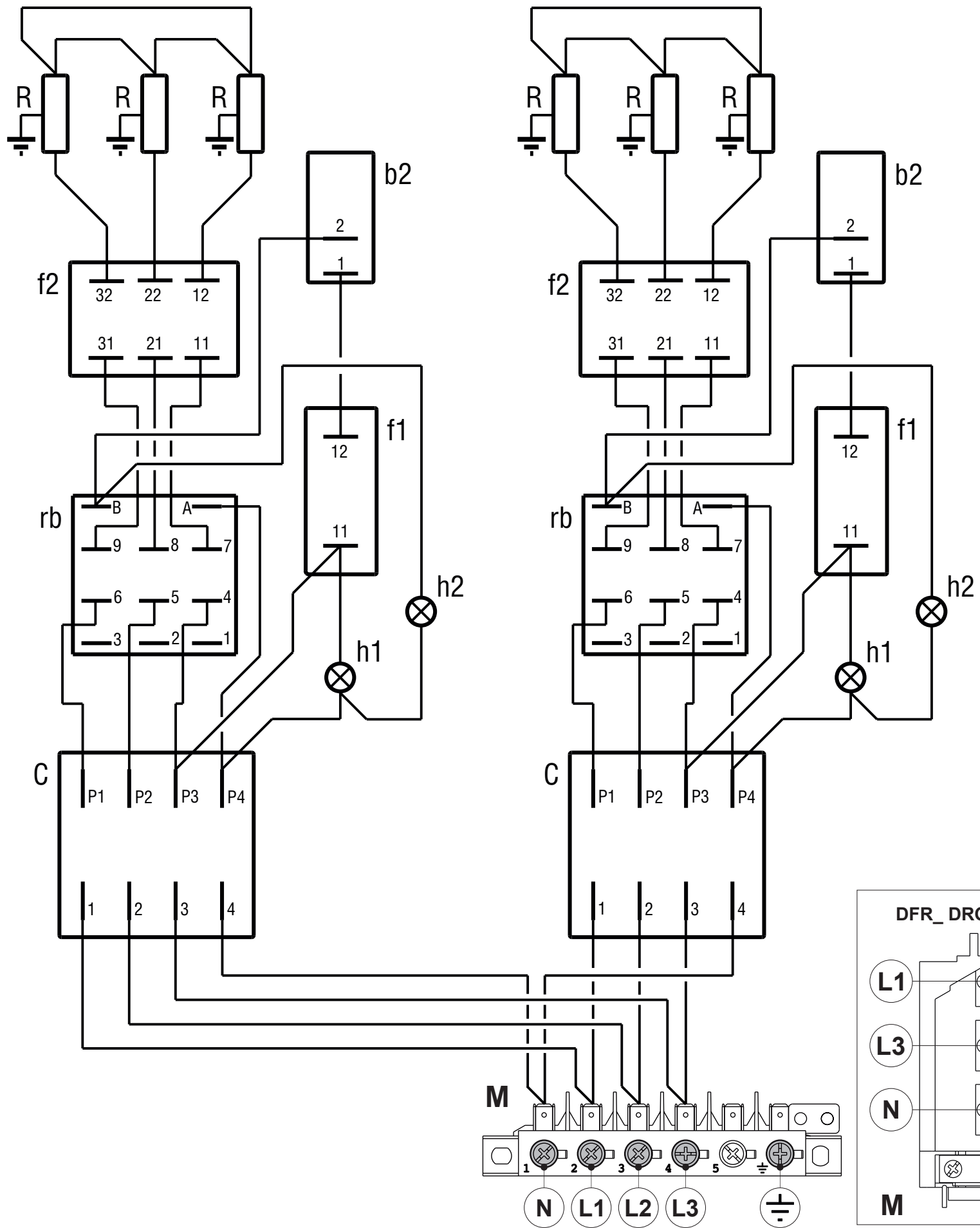

5415.002.03
 SCHEMA ELETTRICO WIRING DIAGRAM
 400V~3N
 Mod. DFR70E0 DFR70ES0
 FR70E/6/0 FR70ES/6/0
 FR70E/0 FR70ES/0
 FR70E7 FR70ES7
 FR8_E7 FR8_ES7