

# SCHALTPLAN

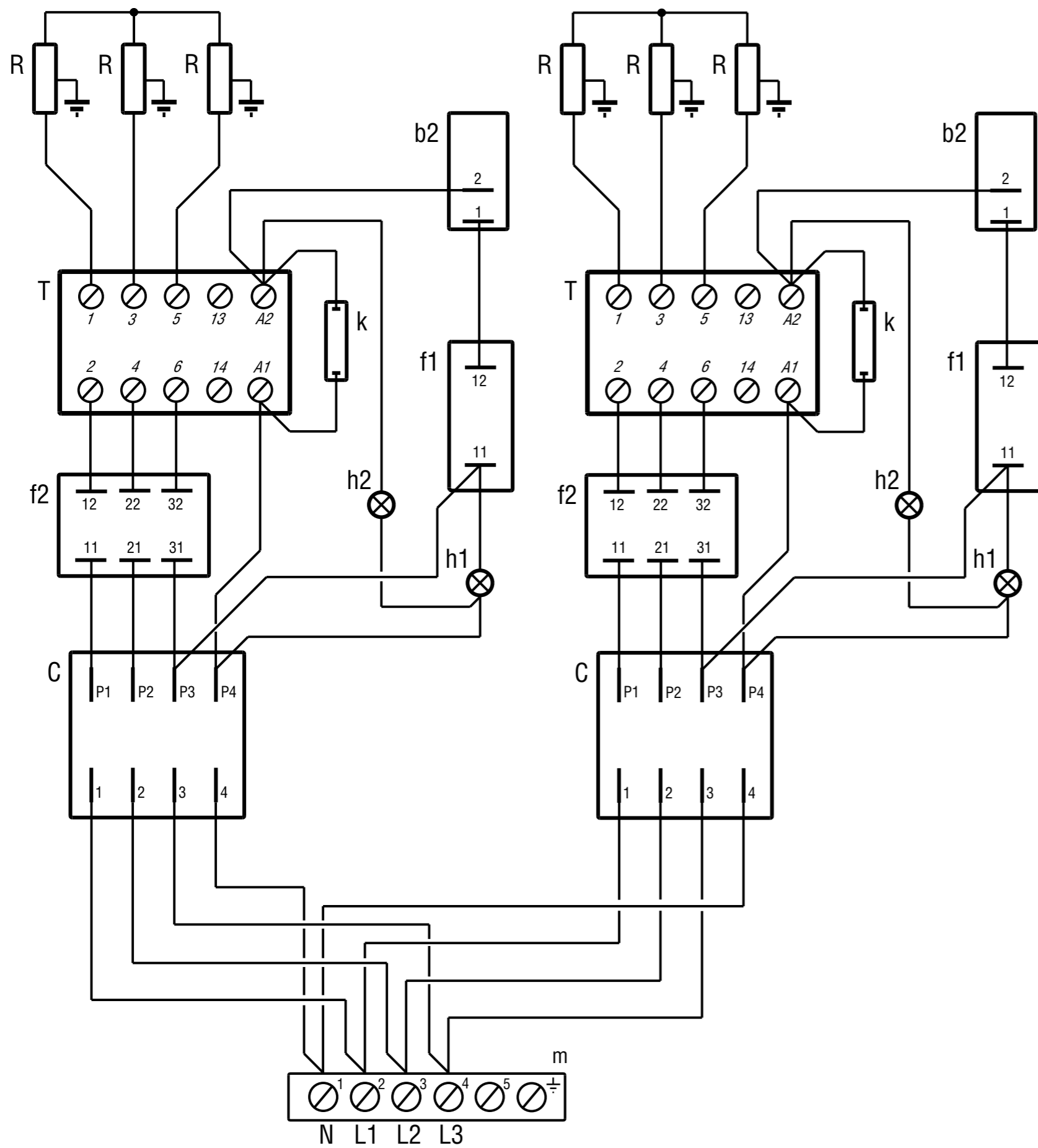

KBS Gastrotechnik GmbH – Schoßbergstraße 26 – 65201 Wiesbaden



k	Filtro antidisturbo	EMC filter
f2	Limitatore di temperatura	Temperature Limiting Device
f1	Termostato di lavoro	Thermostat
b2	Interruttore di sicurezza	Security Switch
h2	Lampada resistenza inserita (arancione)	Running Heating Element Lamp (orange)
h1	Lampada presenza tensione (verde)	Tension Signal Lamp (green)
C	Commutatore	Switch
T	Teleruttore	Remote control switch
R	Resistenza elettrica	Heating Element
m	Morsettiera	Main Terminal Block

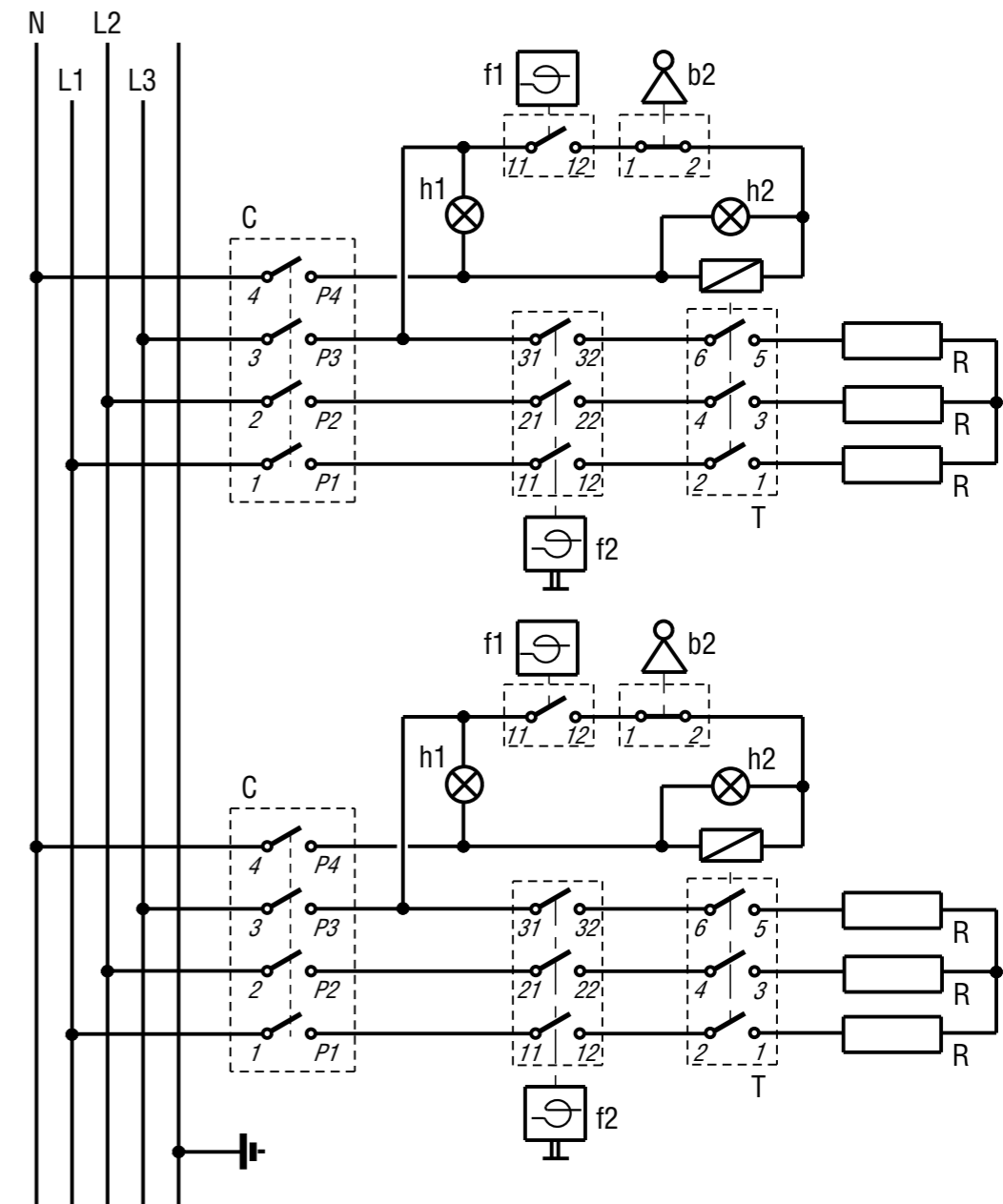

**5415.430.00**  
 SCHEMA ELETTRICO WIRING DIAGRAM  
 400V~3N  
 Mod. FRS70E7