

# SCHALTPLAN



KBS Gastrotechnik GmbH – Schoßbergstraße 26 – 65201 Wiesbaden

5415.353.00

SCHEMA ELETRICO WIRING DIAGRAM

400V~3N

Mod. EFR70EV7

PFR70V7

PFR70V7/1 - PFS70V7

PFU70V7

PR8V7

PFR8V7/1 - PFS8V7

PFU8V7

PFU8VE9

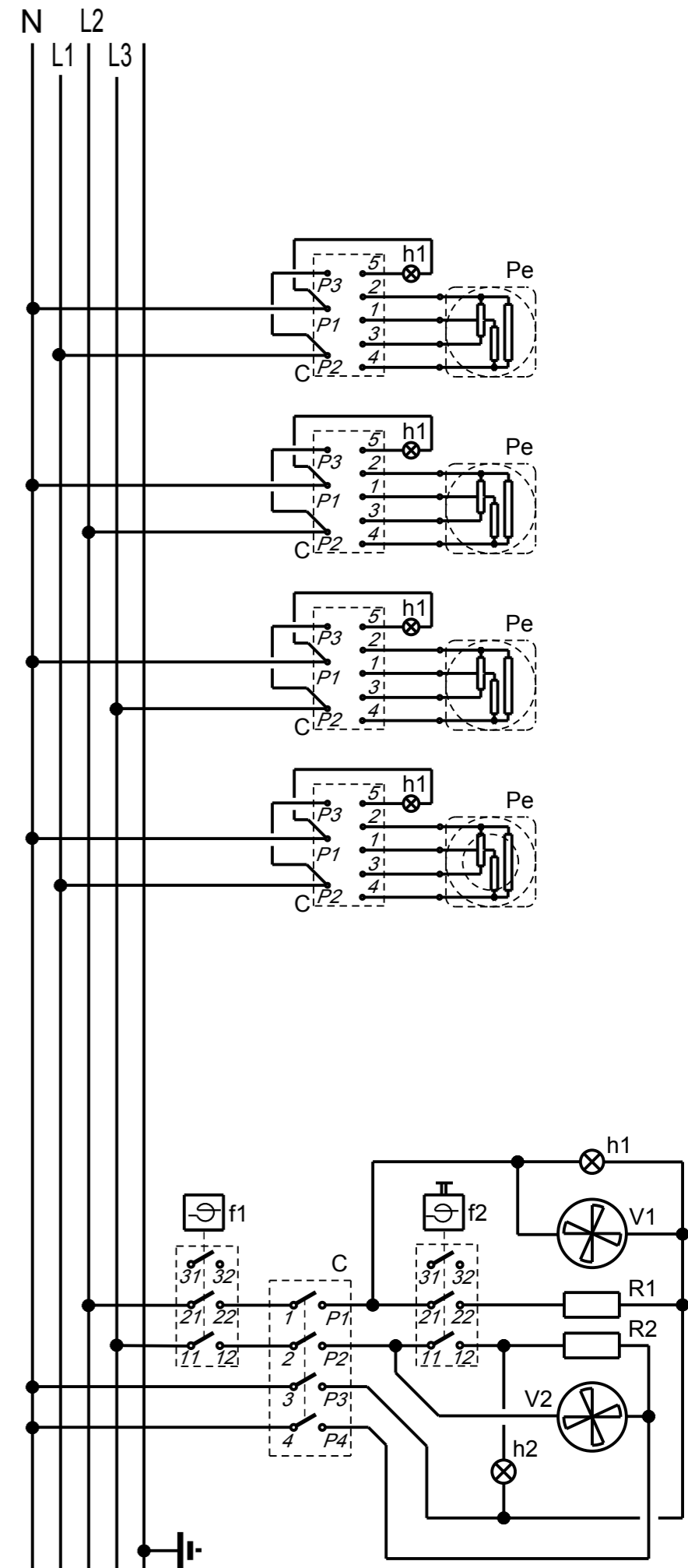
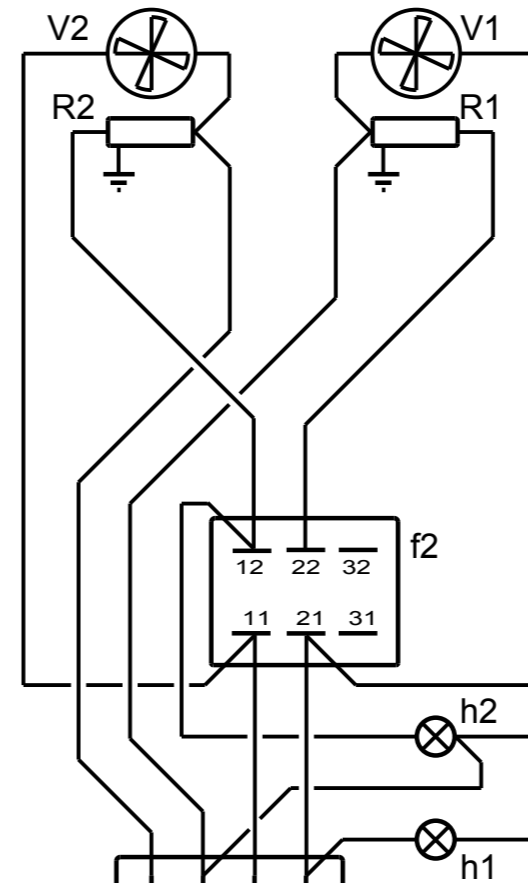
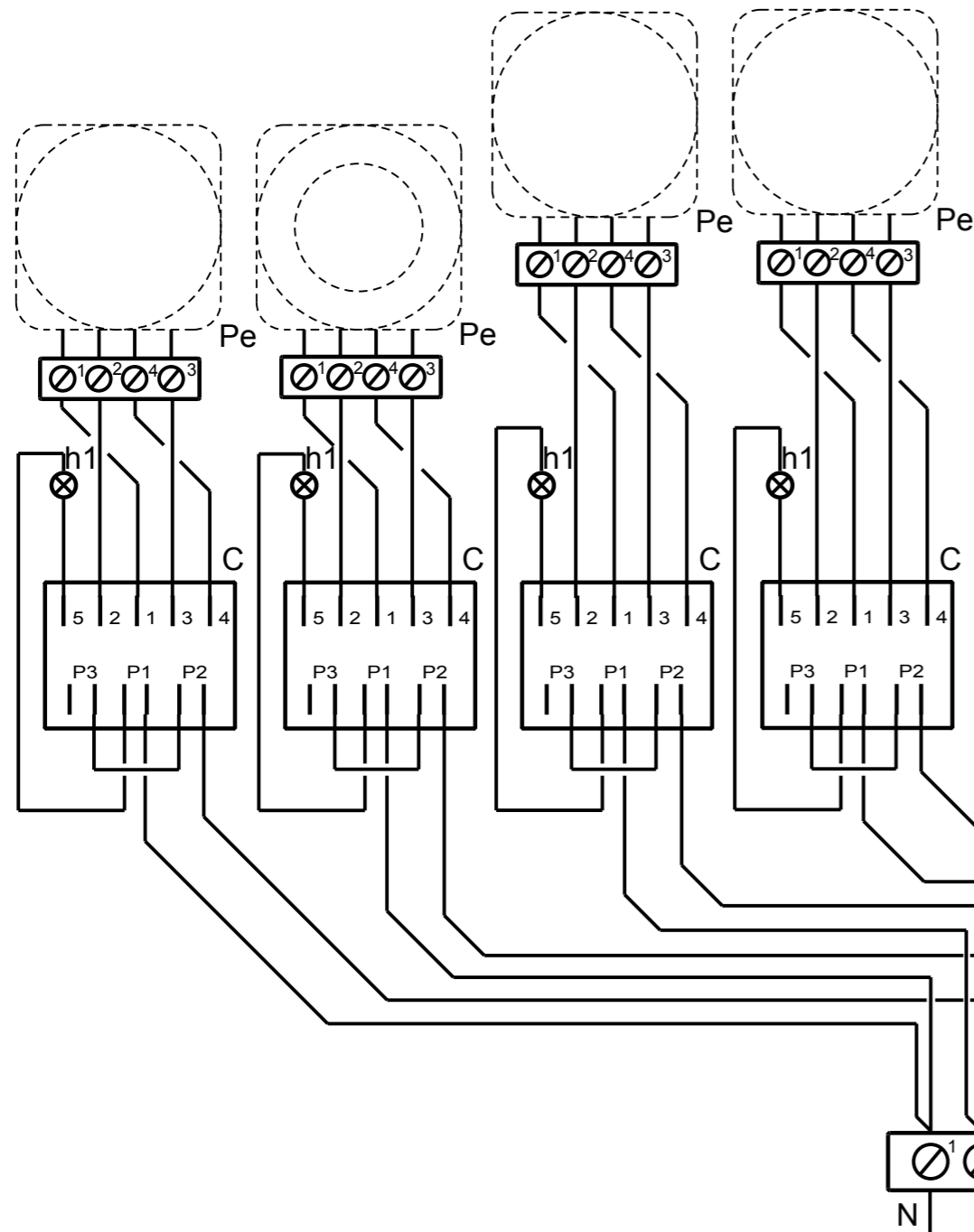

SCHEMA COLLEGAMENTO COMMUTATORE

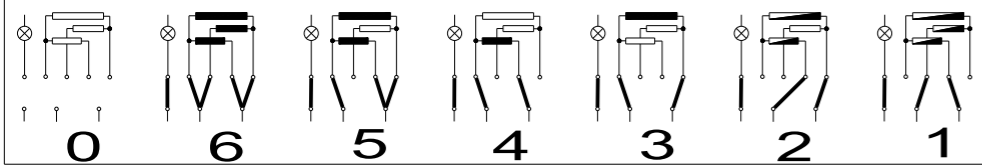

Pe	Piastra elettrica	Hot Plate
f1	Limitatore di temperatura	Temperature Limiting Device
f2	Termostato di lavoro	Thermostat
h1	Lampada presenza tensione	Tension Signal Lamp
h2	Lampada funzionamento	Working Signal Lamp
C	Commutatore	Switch
V	Ventola	Fan
R	Resistenza elettrica	Heating Element
m	Morsettiera	Main Terminal Block